



LP-NP Water Leak Non-locating Panel

Quick Start Guide



General Note

To ensure normal operation, please follow thru various instructions listed in this manual.

The LP-NP water leak non locating panel is designed to detect liquid leak of the sensing cable up to 100m. Once liquid leak is detected, the LP-NP water leak locating panel gives an audible and visual alarm and the relay output is energized. The communication Protocol of LP-NP water leak locating panel is Modbus RTU which is easy to interface with BMS systems.

LP-NP can be either stand alone or interfacing with the BMS system.

Its application includes Data Centre, Warehouse, library, museum and so on.

Product Features:

- LED light shows Power, Leak, Cable Fault, and Communication Status
- Serial RS-485 communication Port with Modbus Protocol
- 12V DC power supply
- NO/NC Relay output is available
- Din rail installation
- 86*70*58 mm in size



Water Sensing Cable

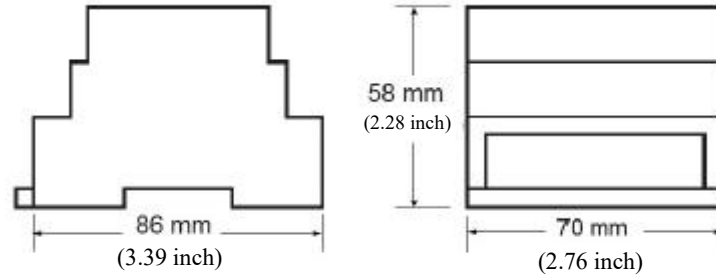

Technical specification

Basic Features	Maximum length of sensing cable	100m
	Accuracy	100%
Ambient	Storage temperature	-40 °C ~60 °C (0 °F~ 140°F)
	Operating temperature	0°C ~45°C (32 °F ~ 117°F)
	Humidity	5%~95% (Non-condensing)
Power Requirements	LP-NP	12-24VDC, 3W
Serial Interface	Network Configuration	RS-485Serial port; different baud rates are available, and the factory default is 9,600; the address is from 0 through to 255, and the factory default is 0
	Communication Protocol	MODBUS RTU
Relay contact	Function	NO/NC contact for leak and sensor fault alarm
	Ratings	DC24V, 1A.



Water Sensing Cable

LP-NP Installation

Choosing Installation Location

The panel should not be installed in any improper environment, temperature limits or severe vibration. LP-NP can be installed in 35 mm DIN rail. Also, IP54 housing is available to the panel. The maximum allowable sensing cable is 100m.

Important: The LP-NP panel is an electronic device. Please take the caution below

- Handle with care and avoid mechanical shock and impact.
- Keep dry.
- Avoid electrostatic discharge to the panel
- Prevent the contact with metal filings, grease, pipe coatings and other contaminants.

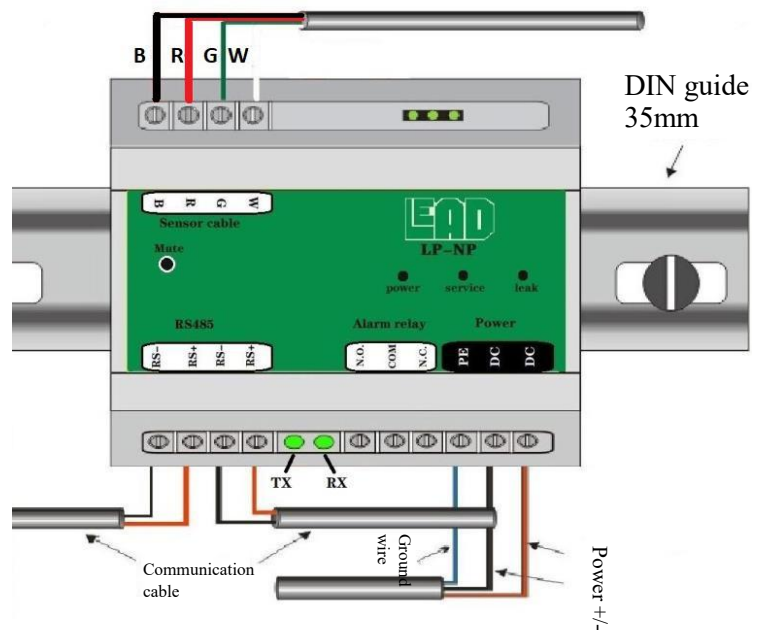

Installation Diagram

Installation of LP-NP

- Install the 35mm Din rail in appropriated flat wall.
- Directly install the LP-NP panel into the Din rail.

Connection between Power Cable and Communication Cable

All LP-NPs are designed with an inbound cable (from the monitoring host system) and an outbound cable (to the next LP-NP). Connect the DC12V power supply (two DC terminals); the PE terminal is power ground that can be connected to achieve favorable immunity from interference. The detailed wiring method is shown in the figure below.



Water Sensing Cable

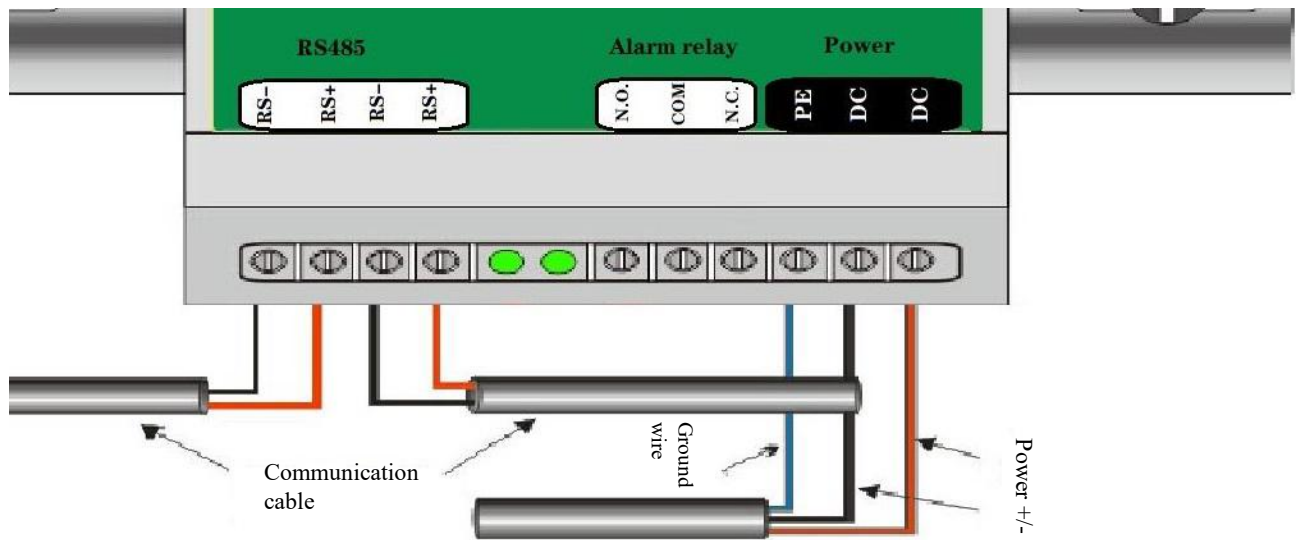

Connection of Alarm Relay

The relay output of LP-NP can be used for local or remote alarm, it can also be used as an digital signal for any BMS system.

Wiring Combination	Alarm Status	Output State
N.O. —COM	No alarm	Open
	Alarm	Closed
	Loss of power	Open
N.C. —COM	No alarm	Closed
	Alarm	Open
	Loss of power	Closed

Connection of Lead-out Wire of Leak Sensing Cable

LP-NP can be used with WS-Lxx leak sensing cable. The leak sensing cable is connected as shown in the following figure.



Water Sensing Cable

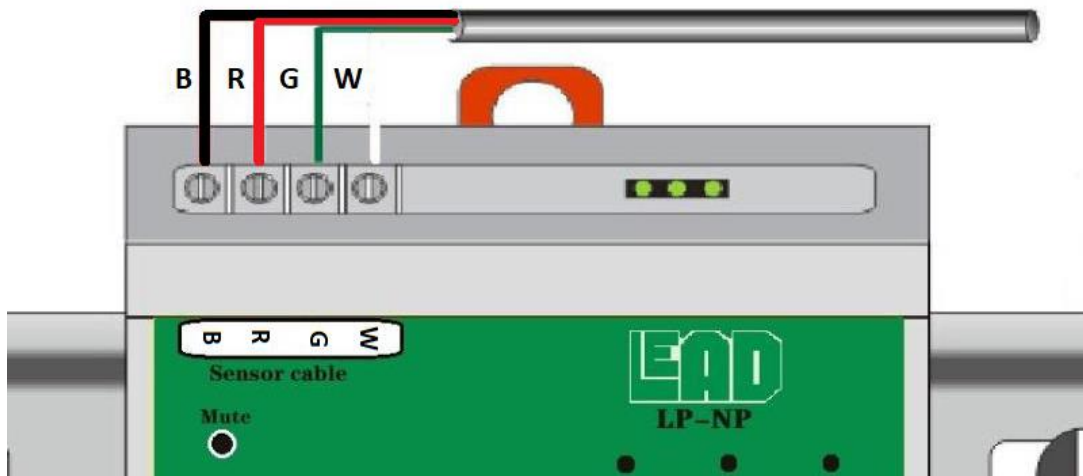

Modbus Address table

Default Setting: ID:1 , Baud Rate 9600, 8N1

03 Holding Register(Signed)

Address	Description
40001	Modbus ID
40002	Baud Rate

04 Read Input Register

Address	Description	Details
30001	System Status	0 = Normal 1 = Leak 2 = Break



Operating Instructions for System Configuration

Setup of Device Address and Baud Rate

If LP-NP is integrated into the monitoring system, LP-NP panel must be assigned address. The factory default address of all LP-NPs is 0 and its baud rate is 9,600. Each LP-NP must be an unique address and same communication baud rate.

Please follow the steps below to set address of LP-NP:

- Power on LP-NP, then turn the communication cable into RS232 signal vial RS485, and connect it to the designated PC.
- Launch the configuration software as shown in the following:

1. Make sure the LP-NP is powered on and the communication line is connected to the designated serial port of a PC (RS232/RS422 signal converter may be needed). Start the modscan32 software to set the Device id and baud rate as shown in the following figure:

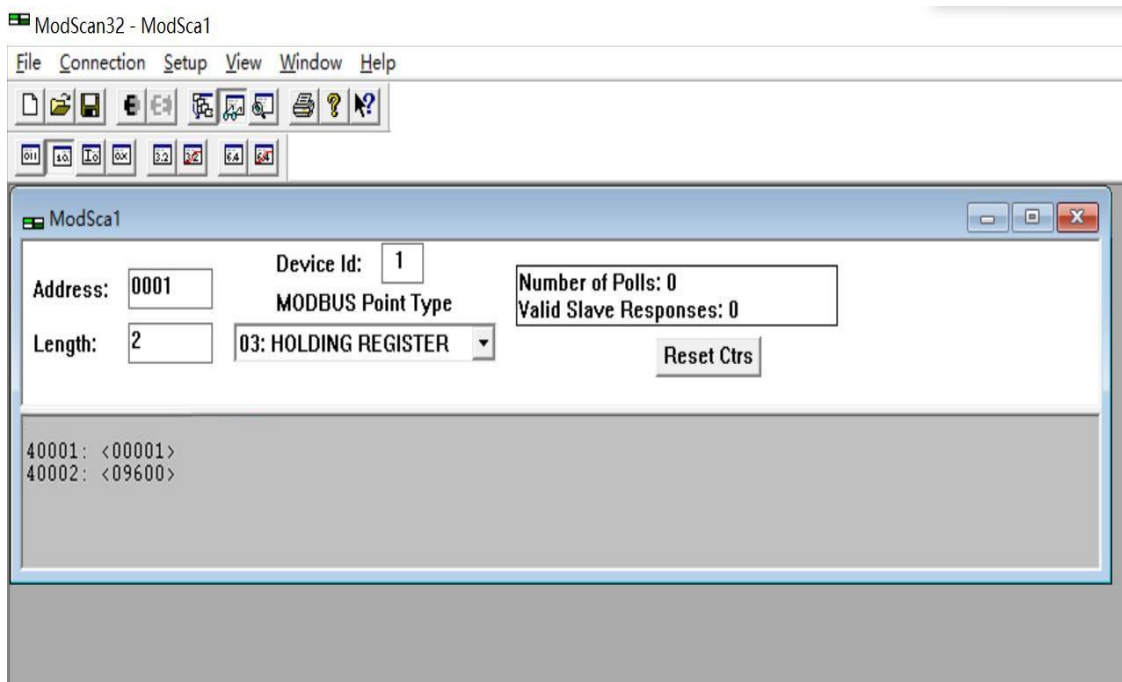

2. As an example, the procedure to change the "Device id" from 1 into 177 is shown in the diagram below:



Water Sensing Cable

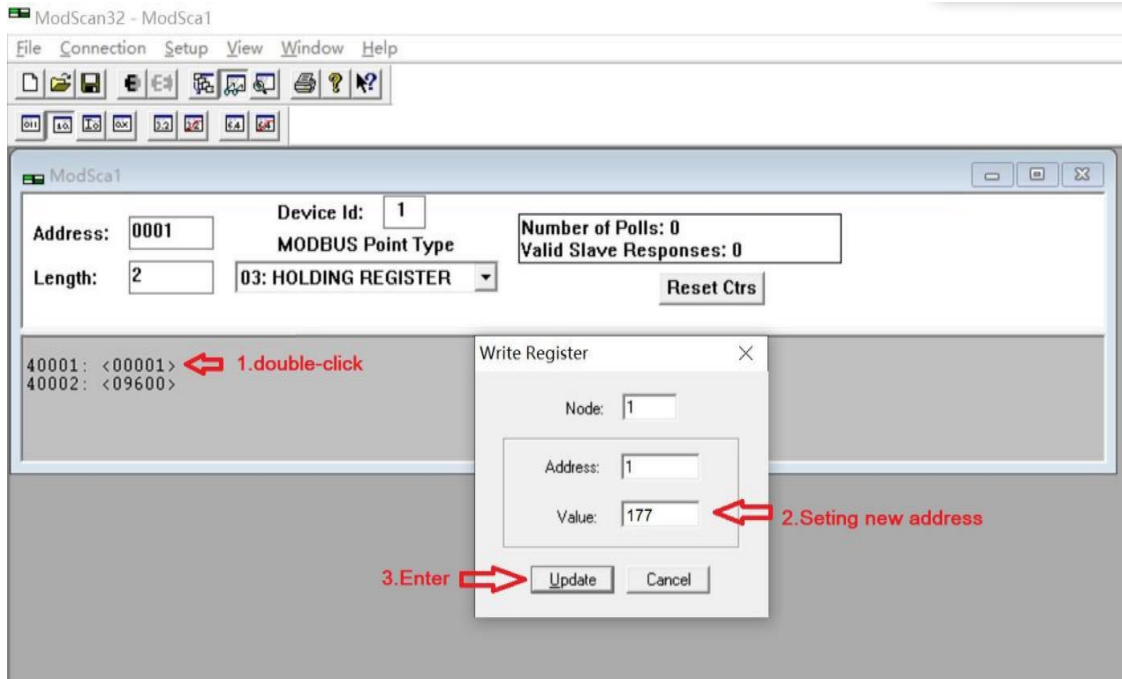

3. In order for the "Device id" to be renewed and become effective, the panel must be turned off and then power up reset. Also, it is always a good practice to restart the Modscan32 software. Please make sure the "Device id" is properly updated, otherwise the software will display communication failure.

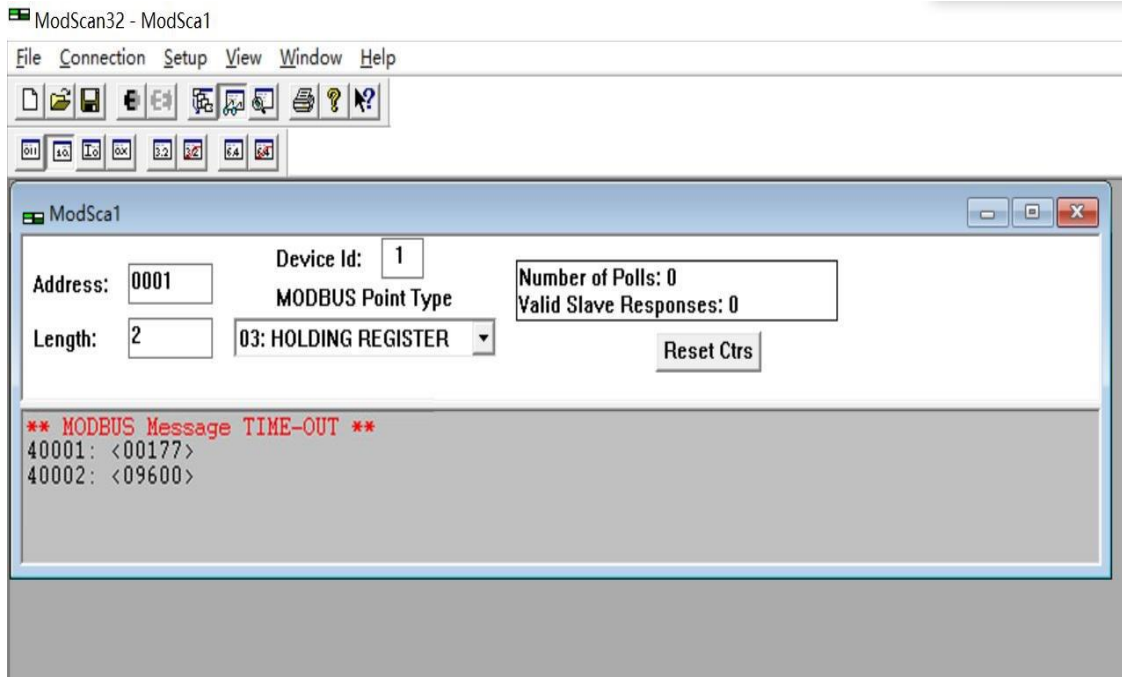

4. After the above steps, the communication can be resumed with the new Device id.



Water Sensing Cable

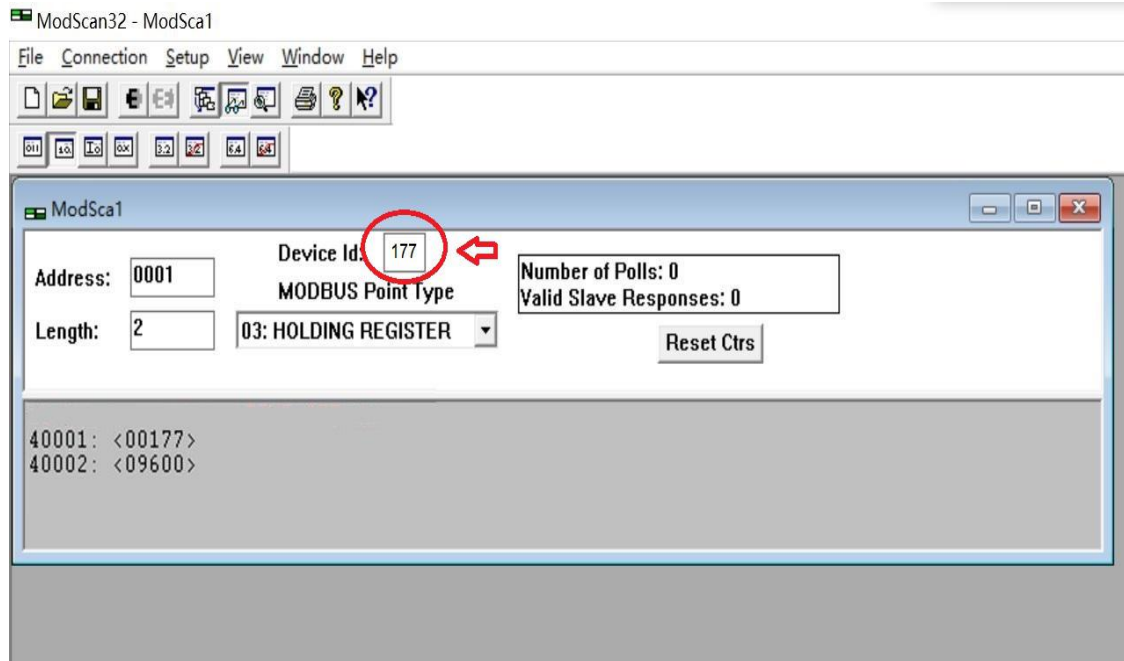

Trouble-Shooting

- Each LP-NP has been tested for reliability and functionality at the factory, and users can directly put it into use without the need for additional testing. Status display There are 5 LEDs on the LP-NP, which respectively indicate: power supply, communication (RX=RECEIVE, TX=TRANSMIT), liquid leakage detected, sensor cable failure or disconnection.
- When the LP-NP is energized and operating correctly, the red power LED is on. Table 1 lists the status of various induction cables and the corresponding possible corrective measures. Table 2 lists various communication statuses (applicable to LP-NP in connected network systems).



Water Sensing Cable

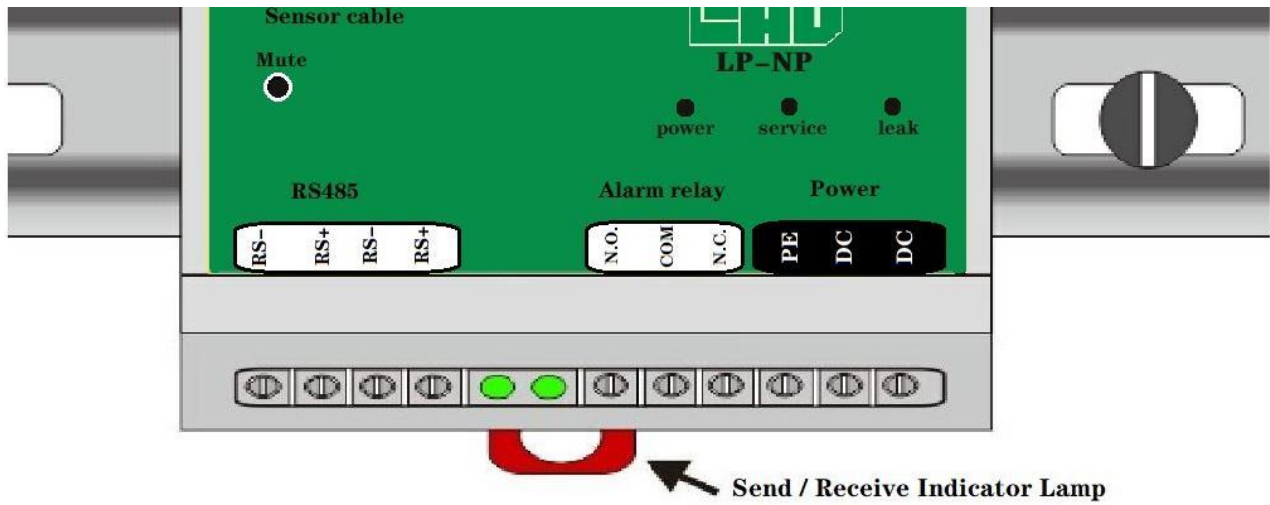

Table 1. LED Indication of the Running Status of LP-NP

Power Indicator(Red)	ON	Normal power-on
	OFF	Abnormal power or fault of LP-NP
FAULT Indicator(Green)	ON	Break or fault or improper connection of sensing cable
	OFF	Proper connection of sensing cable
LEAK Indicator(Green)	ON	Leak
	OFF	There is no leak

Table 2. LP-NP Communication Status Indication

TX(TRANSMIT)	RX(RECEIVE)	State
Flash	Flash	The LP-NP normally communicates with the Master
OFF	Flash	The LP-NP receives information from the Master and no
OFF	Normally ON	The RS485 communication cable was shaken by AB or the communication chip malfunctions
OFF	OFF	LP-NP does not communicate with the Master



Maintenance

- It is recommended to conduct quarterly check on LEAD leak detection system performance by authorized LEAD distributors/installers.
- During quarterly checking and maintenance:
 - Check physically on the sensing cable surface cleanliness and free from any chemical contact.
- For any parts replacement or extension, LEAD local distributors offer ex-stock and will provide an immediate turnaround service to meet the requirements.